

TN-35AF TN-35EF

Five Spindles(A)

全自動高速捲線機(5錠)

Automatic Sewing Thread
Cross Cone Winder

Max 1600 m/mim
Max 10000 r.p.m

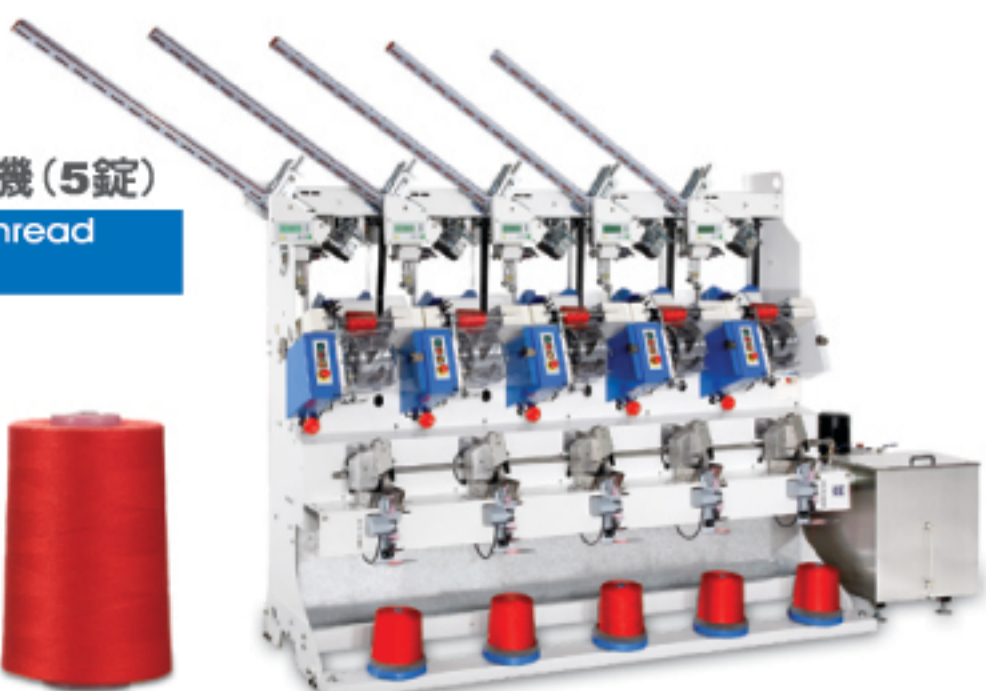

A型管專用繞線機超強多功能

自動送管與落紗系統

- ⊗ 自動落紗，採用凸輪作動方式，動作準確、快速。
- ⊗ 機器壽命與動作不受空氣品質與壓力影響。

全單錠控制系統

- ⊗ 電腦自動控制線速，自動計長，長度準確。
- ⊗ 可設定每分鐘300-1600米之線速度。

自動上油裝置

- ⊗ 可直接設定不同之油輪速度，搭配穩定線速度，使上油均勻。

滾筒式導線系統

- ⊗ 導線凸輪採用組合式不銹鋼三角導片，表面硬路處理光滑耐磨，不傷紗線。

電磁式張力系統

- ⊗ 電磁式張力可設定起步張力與最終張力持續遞減，使成型美觀一致。

循環式過油裝置(選配)

- ⊗ 一只油箱可供30錠機器共用，每錠經常保持滿油位。

35AF特性

- ⊗ 繞線採用伺服馬達排線系統，線密度與花紋回數可直接電腦設定自動調整，不用手動調整或更換齒輪。

其他特性

- ⊗ 縫紉線、SP線、棉紗線、滌綸線，A,H型管適用。
- ⊗ 繡花線、尼龍線、錦綸線、邦迪線，Y型管適用。
- ⊗ 人造纖維、化纖絲、人造絲等特殊纖維必須實際測試才能確認是否適合捲繞。

Cone type bobbin / Powerful multi-function

Automatic mechanical bobbin doffing system.

- ⊗ Mechanical bobbin doffer.
- ⊗ No pneumatic devices, no need air compressor.

Individual spindle control.

- ⊗ Computer yarn length measurement.
- ⊗ Yarn speed adjustable from 300~1,600 meters/per minute.

Auto lubrication system.

- ⊗ Lube roller speed is adjustable & proportional to yarn speed.
- ⊗ Dosing pump lube system is also available.(optional)

Drum thread guiding system.

- ⊗ High speed,low noise operation.
- ⊗ Drum with special hardened polish treatment,smooth & wear resistance.

Electro-magnetic tension device.

- ⊗ Automatic tension release throughout the cycle for consistent winding tension.

Circulating oiling tank.

- ⊗ Oil tank good to be connected for 30 spindles.
- ⊗ Hot lube tank is also available.(with temperature controller)

TN-35AF Advantage

- ⊗ Servo control system.
- ⊗ Computerized yarn laying & electronic gears for easy number of crossing input.

Other characteristics.

- ⊗ Cone,Spool type is available for S.P threads, cotton threads & sewing threads.
- ⊗ Kingspool type is available for embroidery threads, nylon threads & bonded threads.
- ⊗ For filaments, fiber yarns, monofilaments & technical threads are subject to final confirmation.

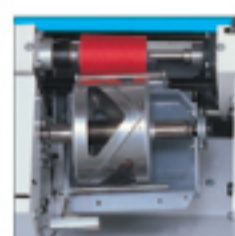

滾筒式
導線裝置
Drum thread-guiding
system



可設定漸減式
電磁張力
Electro-magnetic
tension



可設定且跟隨
線速之上油裝置
Lick-roller
lube system



多功能微電腦
控制面板
Control Panel

機器外觀尺寸圖/Outlook Dimension

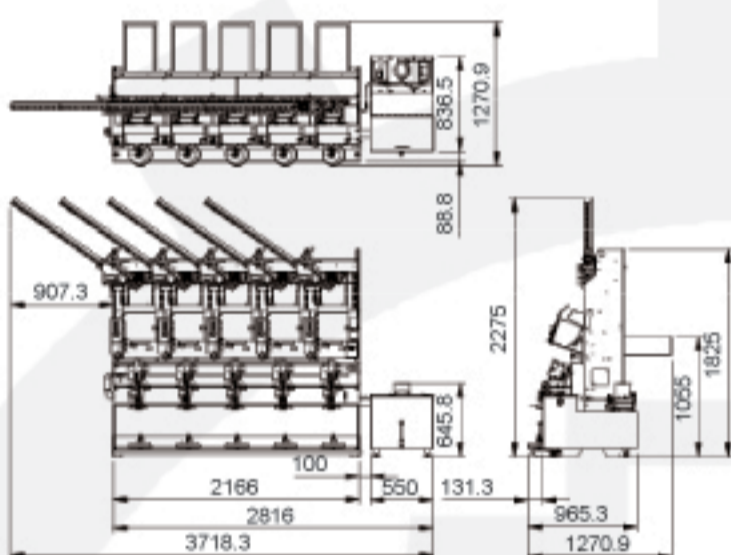
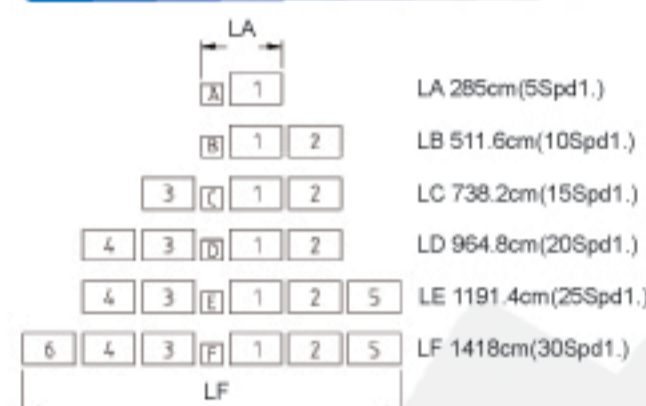

主要規格/Main Specifications

成型 / Package shape	
管子角度 Taper angle	220°~557°
最大產量 Max.Capacity	180 LBS/8hrs 40/2 SP
最大捲取外徑Max. Outer dia ∅	110mm
橫動量 Traverse	3"-4"
錠數 No. of spindle	5
主軸速度 Spindle speed	Max 10000 r.p.m
線速度 Yarn speed	Max 1600 m/min
花紋回數 Cross ratio	5-8F
機器重量 Weight	N.W.900kgs G.W.1100kgs
包裝材積 Measurement	230L x 90W x 190H(cm)

選擇性配備/Optional

1. 循環式油箱
Circulating oiling tank
2. 循環式加熱油箱
Hot Circulating oiling tank
3. 省能計量上油系統
Dosing pump lubrication system
4. 伺服繞線系統
Servo winding system



機器設計及規格如有變更恕不另行通知，本機器獲得多項專利，仿冒必究

All specifications and designs subject to change without notice.



泰能機器工業股份有限公司
TAINING MACHINE INDUSTRIAL CO., LTD.
台灣台中縣大肚鄉沙田路三段734巷35號
35, Lane 734, Sec 3, Sha Tien Rd. Ta-Tu,
Taichung Hsien, 432 Taiwan
TEL: 886-4-26991213 FAX: 886-4-26996533
E-mail :taining@ms14.hinet.net
http://www.taining.tw
www.taining.com.tw
www.winder.com.tw

盈侖股份有限公司
INWIN W & R CORPORATION
78, Tu Hsin Rd. Taichung 404 Taiwan
TEL: 886 - 4 - 23010980 (23013581)
FAX: 886 - 4 - 23012267 (22027541)
E-mail: taining.inwin@gmail.com



ISO 9001