



Model - A



TN-35A全自動高速繞線機-A型管
Automatic High Speed Cross Cone Winder(Cone Type)



Model - Y

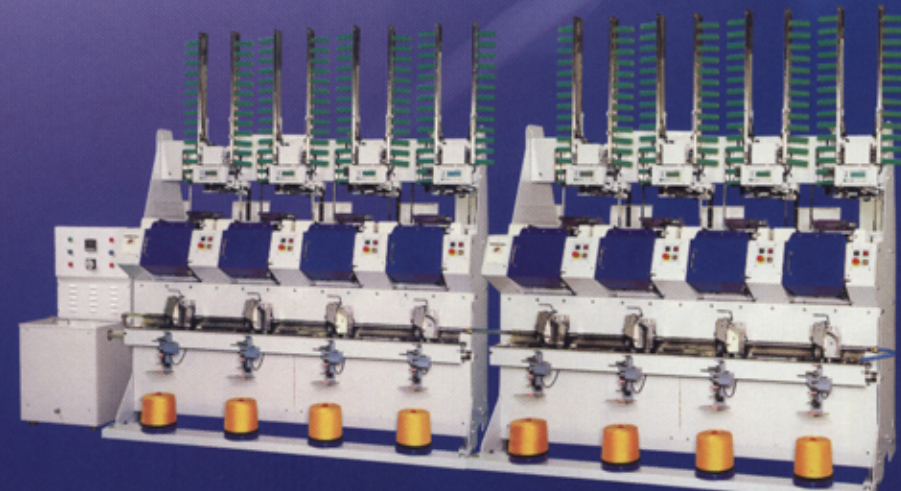

TN-35A全自動高速繞線機-Y型管
Automatic High Speed Cross Cone Winder(King Spool Type)



Model - H



TN-35A全自動高速繞線機-H型管
Automatic High Speed Cross Cone Winder(Spool Type)

超強多種功能

自動送管與落紗系統

- 自動送管，無管自動停車。
- 落紗採用凸輪帶動方式，動作準確、快速。
- 機器壽命與動作不受空氣品質與壓力影響。
- 換管動作只需7秒。

單錠控制系統

- 電腦自動計長，不必經過輪子或滾輪，準確度±0.5%。
- 自動控制線速度，可任意設定每分鐘300~1600米之線速度。
- 可直接設定不同之油輪速度，搭配穩定線速度使上油均勻。
- 輸入不同線規格時，可自動調整線排列之密度與花紋。
- 以上功能有250組記憶模組，並能夠設定生產數量。

滾筒式導線系統

- 採直接導線方式，速度快、聲音小
- 導線凸輪採用特殊硬化拋光處理，光滑耐磨，不傷紗線。

電磁式張力系統

- 可設定起步張力與最終張力持續遞減，使成型美觀一致。

循環式過油系統

- 每錠經常保持滿油位。
- 每個油輪均附有濾油裝置，防止油外噴與浪費油。
- 油輪可跟隨線速度。
- 大型回流油槽與擋油板，可承接作業中產生之棉絮與油回流並過濾不污染地面。
- 一只油箱可供24錠機器共用。
- 可拆式濾網，清理容易。

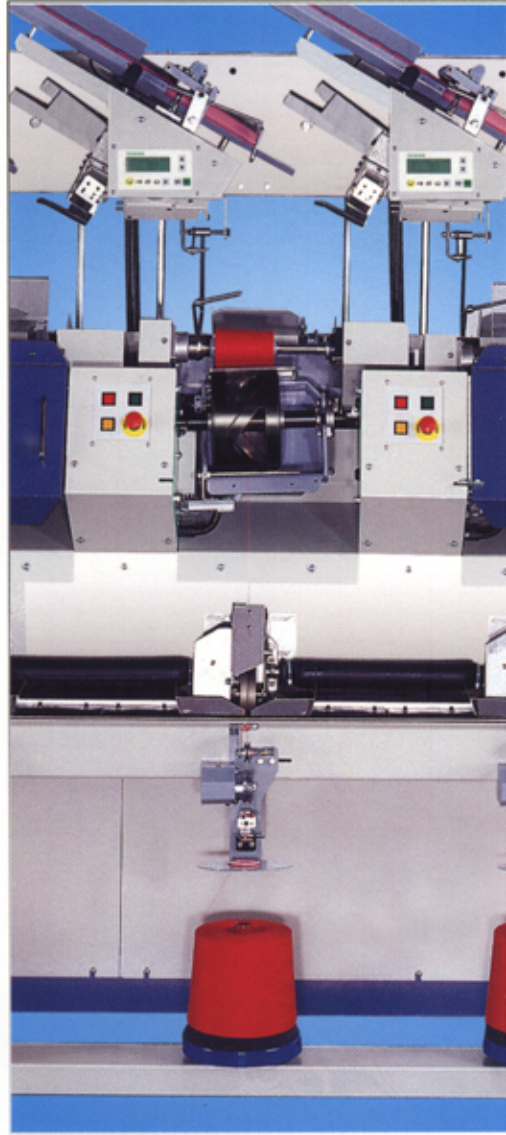

Powerful Multi-function

Auto Bobbin Feeder and Doffing system

- Offer automatic stops when bobbins run out.
- Mechanical system. No pneumatics, air quality, or air pressure to affect the service life and performance of the machine.
- Quick action, accurate timing, and durable.
- 7 seconds doffing time.

Individual Spindle Control

- LCD display.
- Yarn length measured by computer, not rollers or wheels. Accuracy within 0.5%.
- Yarn speed adjustable from 300 to 1600 meters/per minute.
- Uniform thread lubrication due to constant yarn speed.
- The oiling roller speed is adjustable and proportional to the yarn speed.
- Density adjustment with different yarn specifications.
- Automatic thread layer option.
- 250 sets of memory functions with production quantity present.

Drum Thread-Guidance System

- High speed, low noise drum.
- Drum with special hardened polish treatment, smooth & wear resist.

Electro-magnetic Tensioner

- Automatic tension release throughout the cycle for consistent winding tension.

Circulating Oil System

- Centralized oil tank feeds 16 spindles.
- Spindle independent oil filter and filter for consistent trouble-free operation.
- Easy to clean, detachable filter.
- Oversized oil fenders and troughs to minimize oil loss and cleaning.

其他特性/Other characteristics

- 適合各種角度之紗管。0°0'~0°57'。
- 機器運轉時，門若打開，則自動停止運轉。
- 非接觸斷紗檢測，感應靈敏。
- 占地面積小、速度快、效率比傳統機器提升5~6倍。
- 全部採用高速軸承，免加油，保養容易。

Additional Features

- High Speed Operation, 5 to 6 times faster than conventional models.
- Supports a wide variety of bobbins from 0°0' to 5°57' degrees.
- Sensitive, contact free thread detector.
- Easy maintenance, oil-free bearings.
- Automatic door lock during operation.
- Small footprint design.

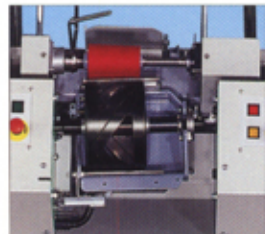

滾筒式導線裝

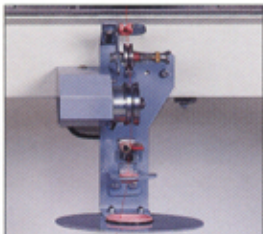

可設定漸減式

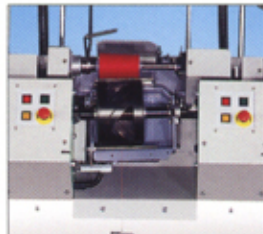

可設定目跟隨



多功能微電腦

選用性配備 / Optional

- 循環式油箱
Circulating oiling tank.
- 循環式加熱油箱
Hot circulating oiling tank.
- 省能計量上油系統
Dosing pump lubrication system



機器外觀尺寸圖 / Outlook Dimension

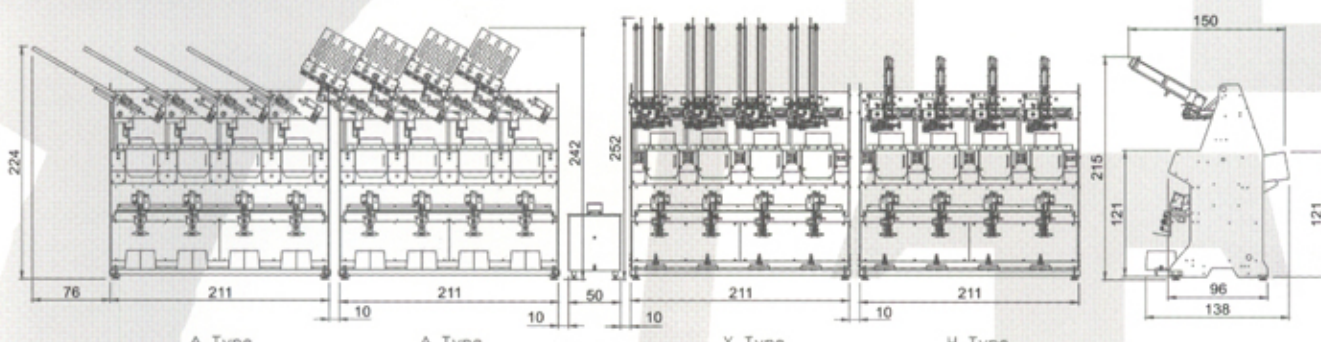

主要規格 / Main Specifications

| 成型 / Package shape | Model - A | Model - H | Model - Y |
|---------------------|-------------------------------|-------------------------|---------------------------|
| 管子角度 Taper angle | 2° 20' ~ 5° 57' | 0° | 0° ~ 2° 20' |
| 產量 Capacity | 150 LBS/8hrs 40/2 SP | 2000 PCS/8hrs 40/2 500M | 250 LBS 8hrs 210D/2 Nylon |
| 最大捲取外徑 Max. outer Ø | 166 mm | 100 mm | 94 mm |
| 橫動量 Traverse | 3" 4" 5" 6" | 2" 3" | 2" 3" 4" |
| 錠數 No. of spindle | 4 | | |
| 主輪速度 Spindle speed | Max 1200 r.p.m. | | |
| 線速度 Yarn speed | Max 1600 m/min | | |
| 花紋回數 Cross ratio | 2~4 | | |
| 包裝材積 Measurement | 225L x 143W x 210 H (cm) | | |
| 機器重量 Weight | N.W : 1100 kgs G.W : 1400 kgs | | |

機器設計及規格如有變更恕不另行通知 All specifications and designs subject to change without notice.



TAIING
泰能機器工業有限公司
 TAINING MACHINE INDUSTRIAL CO., LTD.
 台灣台中縣大肚鄉沙田路三段734巷35號
 35, Lane 734, Sha Tien Rd. Sec 3 Ta-Tu,
 Taichung Hsien, 432 Taiwan
 TEL: 886-4-26991213 FAX: 886-4-26996533
 E-mail: taining@ms14.hinet.net
 http://www.winder.com.tw

INWIN
盈俞股份有限公司
 INWIN W & R CORPORATION
 78, Tu Hsin Rd. Taichung 404 Taiwan
 TEL: 886-4-22013581 • 22013582
 FAX: 886-4-22027541 • 22023583
 E-mail: inwin.tw@msa.hinet.net



ISO 9001